



**CITY OF CEDARBURG  
A MEETING OF THE LANDMARKS COMMISSION  
THURSDAY, JANUARY 8, 2026 – 8:30 AM**

A meeting of the Landmark's Commission of the City of Cedarburg, Wisconsin, will be held on Thursday, January 8, 2026 at 8:30 AM. The meeting will be held in-person at City Hall, W63 N645 Washington Avenue, Cedarburg, WI., on the lower level, Room 1.

AGENDA

1. CALL TO ORDER
2. ROLL CALL
  - A. Chairperson Tom Kubala, Council Member Kristin Burkart, Vice Chairperson Jame Pape, Tomi Faye Forbes, Erin Puro, Elizabeth Krimmel, Douglas Yip
3. STATEMENT OF PUBLIC NOTICE
4. APPROVAL OF MINUTES
  - A. November 13, 2025
5. COMMENTS AND SUGGESTIONS FROM CITIZENS
6. REGULAR BUSINESS; AND ACTION THEREON
  - A. Review, discussion, and possible action/recommendation to the Plan Commission on the request of applicant Jewish Discovery Center (in c/o Mosche Luchins) for approval to place a permanent accessory structure in the front yard of their building located at W61 N510 Washington Avenue. This property, owned by Center for Jewish Life LLC, is zoned B-3 Central Business District with Historic Preservation Overlay.
7. COMMENTS AND ANNOUNCEMENTS BY LANDMARKS COMMISSIONERS
8. ADJOURNMENT

City of Cedarburg is an affirmative action and equal opportunity employer. All qualified applicants will receive consideration for employment without regard to race, color, religion, sex, disability, age, sexual orientation, gender identity, national origin, veteran status, or genetic information.

City of Cedarburg is committed to providing access, equal opportunity and reasonable accommodation for individuals with disabilities in employment, its services, programs, and activities. To request reasonable accommodation, contact the Clerk's Office, (262) 375-7606, email: [cityhall@cityofcedarburg.wi.gov](mailto:cityhall@cityofcedarburg.wi.gov).

MEMBERS – PLEASE NOTIFY CITY PLANNER'S OFFICE IF UNABLE TO

ATTEND THIS MEETING.

A regular meeting of the Landmarks Commission, City of Cedarburg, Wisconsin, was held Thursday, November 13, 2025 at Cedarburg City Hall, W63 N645 Washington Avenue, lower level, Room 1.

1. The meeting was called to order by Chairperson Tom Kubala at 8:30 a.m.

2. Roll Call: Present – Chairperson Tom Kubala, Vice Chairperson James Pape, Council Member Kristin Burkart, Tomi Fay Forbes, Doug Yip, Erin Puro

Excused – Elizabeth Krimmel

Also Present – Building Inspector Jeff Thoma

### **3. STATEMENT OF PUBLIC NOTICE**

Chairperson Kubala acknowledged that the agenda for this meeting was posted and distributed in compliance with the Wisconsin Open Meetings Law.

### **4. APPROVAL OF MINUTES**

Motion made by Commissioner Yip and seconded by Council Member Burkart to approve the minutes of the October 23, 2025 meeting. Motion carried without a negative vote. Commissioner Krimmel excused.

### **5. COMMENTS AND SUGGESTIONS FROM CITIZENS** – none

### **6. REGULAR BUSINESS**

#### **REVIEW, DISCUSSION AND POSSIBLE APPROVAL OF THE PROJECTING SIGN FOR RAEZIE BOUTIQUE LOCATED AT N58 W6208 COLUMBIA ROAD. THIS PROPERTY IS ZONED B-3 CENTRAL BUSINESS DISTRICT WITH HPD HISTORIC PRESERVATION OVERLAY DISTRICT.**

Sophie Bollech and her mother, Ashley Bollech, represented the Raezie Boutique. The sign meets the city's sign code criteria and will be mounted in the existing bracket. It needs to be firmly attached so it does not sway.

Motion made by Council Member Burkart to approve the sign, Commissioner Yip seconded the motion. Motion carried without a negative vote. Commissioner Krimmel excused.

**REVIEW, DISCUSSION, AND POSSIBLE APPROVAL OF A WINDOW SIGN PROPOSED TO BE DISPLAYED IN SUPPORT OF THE APPLICANTS PLANNED TEMPORARY USE/POP-UP SHOP, THE READING NEST, TO BE LOCATED WITHIN THE VALLEY SKIN STUDIO BUSINESS SPACE LOCATED AT W63 N672 WASHINGTON AVENUE. APPLICANT IS KRISTIN BURKART. PROPERTY OWNER IS Z VENTURE LLC. THIS PROPERTY IS ZONED B-3 CENTRAL BUSINESS DISTRICT W/HPD HISTORIC PRESERVATION OVERLAY DISTRICT.**

Council Member Burkart is offering a pop-up bookstore inside the Valley Skin Studio for specific times through the holiday season. This is not a permanent sign. It will be placed inside the lower left window when the store is open. It is being treated as a window sign and falls well within the size limitations. Chairperson Kubala commented that he wishes more signs downtown were as appealing as this sign.

Motion made by Commissioner Pape, seconded by Commissioner Puro, to approve the sign. Council Member Burkart recused from the vote. Motion carried without a negative vote. Commissioner Krimmel excused.

**7. ADJOURNMENT**

A motion was made by Commissioner Puro, seconded by Commissioner Yip, to adjourn the meeting at 8:37 a.m.

Tomi Fay Forbes  
Secretary

# PLANNERS REPORT

**To:** City of Cedarburg Landmarks Commission

**By:** Mary Censky

**Date Prepared:** January 8, 2026

## General Information:

**Agenda Item:** 6.A.

**Applicant:**

Jewish Discovery Center (in c/o  
Mosche Luchins)

**Property Owners:**

Center for Jewish Life LLC

**Requested Action:**

Recommendation to the Plan  
Commission for placement of a new,  
permanent accessory structure in the  
front yard.

**Current Zoning:**

B-3 Central Business District w/  
Historic Preservation District Overlay.

**Proposed Zoning:**

B-3 Central Business District w/  
Historic Preservation District Overlay.

**Location:**

W61 N510 Washington Avenue

---

## Discussion:

The applicant presents a drawing of the menorah structure they would like to install permanently in the front yard of this site. They represent that the placement of the structure is on private property, not in the sidewalk right-of-way, based upon an old survey of their site. There is at least 3-feet of clear space behind the back edge of the curb, and an additional 5-feet of clear space beyond that, extending toward the building, for terrace and pedestrian way.





**LANDMARKS COMMISSION APPLICATION**

PROPERTY LOCATION/ADDRESS: W61N510 Washington Ave

NAME OF EXISTING/PROPOSED BUSINESS (IF APPLICABLE): Jewish Discovery Center

**APPLICANT INFORMATION**

APPLICANT NAME: Masha Lochins BUSINESS NAME: Jewish Discovery Center

APPLICANT/BUSINESS ADDRESS: W61N510 Washington Ave

STATUS OF APPLICANT:  OWNER  AGENT  BUYER  TENANT  OTHER

PHONE: [REDACTED] EMAIL: [REDACTED]

**PROPERTY OWNER INFORMATION**

PROPERTY OWNER NAME (IF DIFFERENT): Center For Jewish Life LLC

PROPERTY OWNER MAILING ADDRESS: W. Mequan Rd Mequan WI 53092

PROPERTY OWNER PHONE: [REDACTED] PROPERTY OWNER EMAIL: [REDACTED]

DESCRIBE REQUEST: We would like to install a 6ft6 menorah in front of our building on our private property centered in front of the building see drawings.

**PLEASE SUBMIT: TEN (10) COPIES OF WRITTEN DESCRIPTION OF PROPOSAL OR REQUEST \* PLUS ELECTRONIC COPY TEN (10) COPIES OF DRAWINGS, SKETCHES, PICTURES OR SURVEY MAPS (11" x 17" MAX) \*PLUS ELECTRONIC COPY MATERIAL AND COLOR SAMPLES (WILL BE RETAINED BY THE CITY) SUBMITTAL DEADLINE: Plans must be received no later than 16 days prior to Landmarks Commission meeting.**

\*ELECTRONIC COPIES MAY BE SENT TO [THANAMAN@CITYOFCEDARBURG.WI.GOV](mailto:THANAMAN@CITYOFCEDARBURG.WI.GOV) OR PROVIDE A THUMB DRIVE

The undersigned certifies that he/she has familiarized themselves with the State and Local codes and procedures pertaining to this application. The undersigned further hereby certifies that the information contained in this application is true and correct. This application shall be signed by the property owner(s).

APPLICANT SIGNATURE: SS [Signature] DATE: 12/9/25

PROPERTY OWNER(S) SIGNATURE: [Signature] DATE: 12/9/25

**FOR CITY STAFF USE ONLY**

LANDMARKS COMMISSION MEETING DATE: \_\_\_\_\_ PLAN COMMISSION REVIEW NEEDED?  YES  NO

ATTACHMENTS (CHECK IF RECEIVED):  TEN WRITTEN DESCRIPTIONS  TEN DRAWINGS, SKETCHES OR MAPS  MATERIAL/COLOR SAMPLES (IF APPLICABLE)

PROPERTY TAX KEY NO: \_\_\_\_\_

4

3

2

1

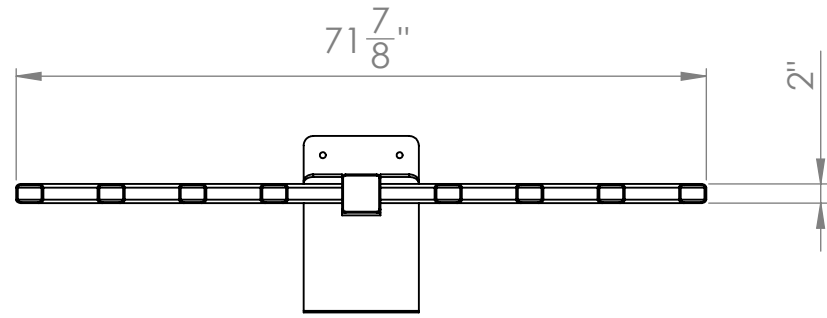

ITEM NO.	PART NUMBER	QTY.	Material	DESCRIPTION
1	MENORAH_01	1	304SS	TUBE 4 X 4 X 3/16 X 84
2	MENORAH_02	2	304SS	TUBE 2 X 2 X 1/8 X 12
3	MENORAH_03	2	304SS	TUBE 2 X 2 X 1/8 X 24
4	MENORAH_04	2	304SS	TUBE 2 X 2 X 1/8 X 36
5	MENORAH_05	2	304SS	TUBE 2 X 2 X 1/8 X 48
6	MENORAH_06	1	304SS	PLATE 3/8 X 12 X 41-1/8

B

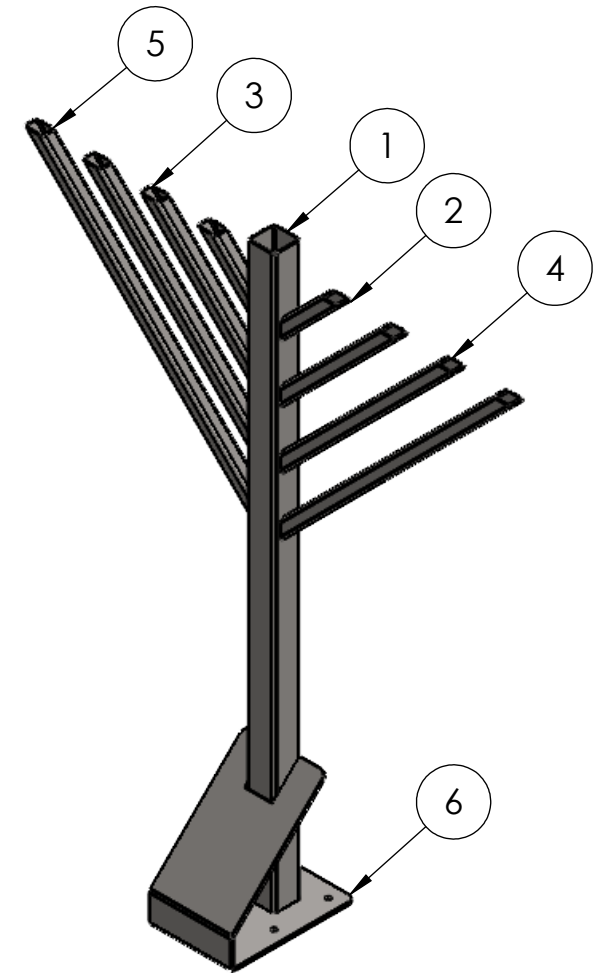
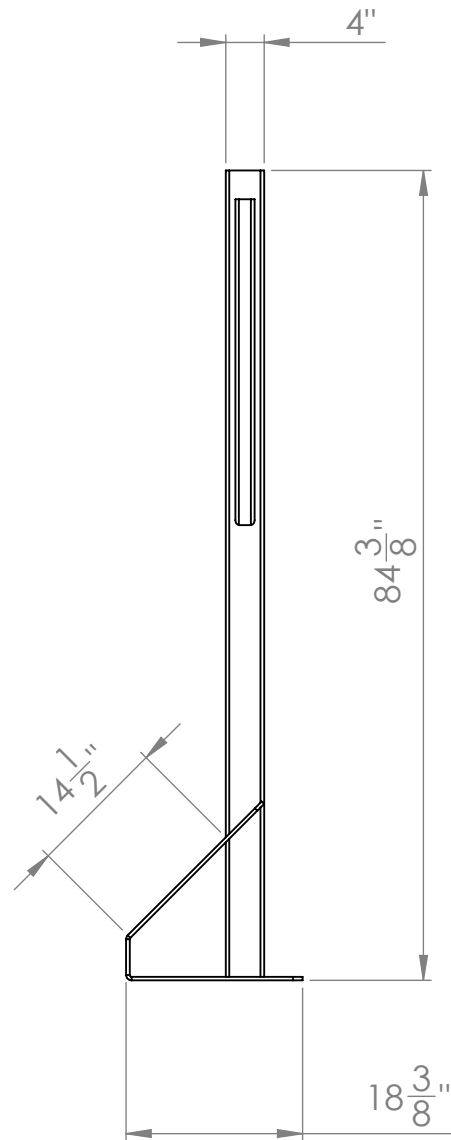
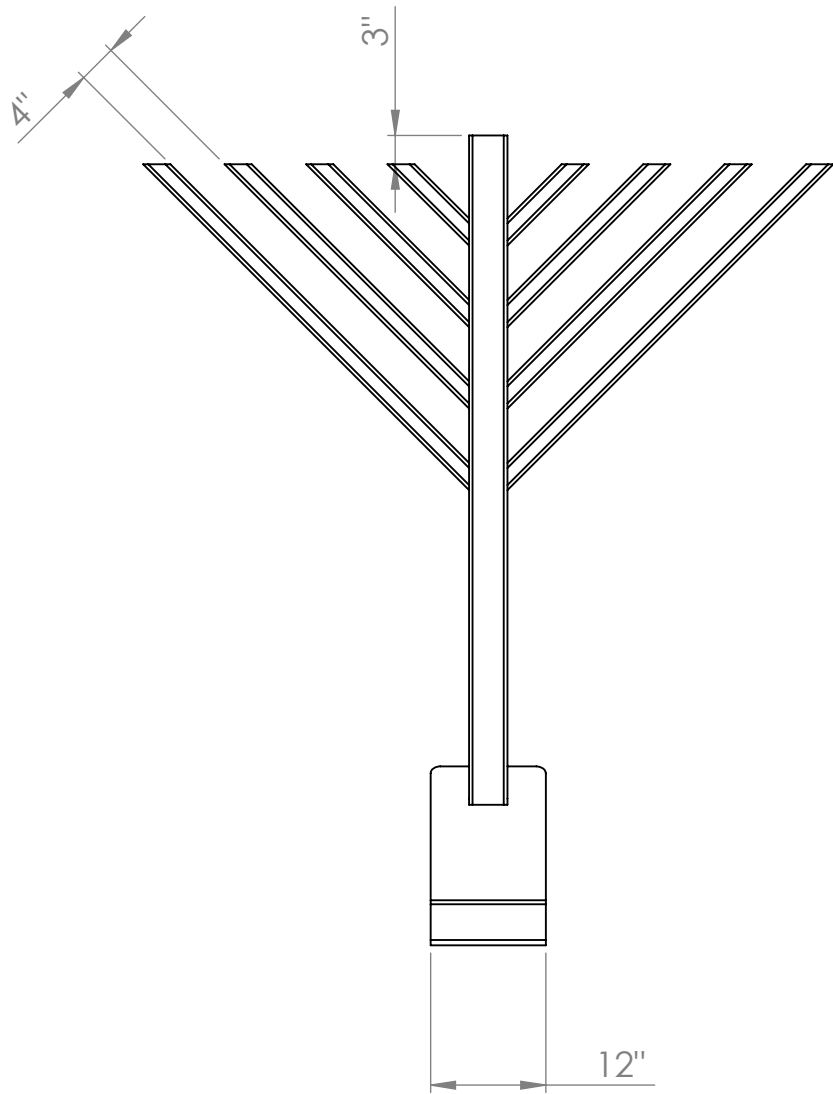

B

A

UNLESS OTHERWISE SPECIFIED:		NAME	DATE
DIMENSIONS ARE IN INCHES		DRAWN	
TOLERANCES:		CHECKED	
FRACTIONAL ±		ENG APPR.	
ANGULAR: MACH ± BEND ±		MFG APPR.	
TWO PLACE DECIMAL ±		Q.A.	
THREE PLACE DECIMAL ±		COMMENTS:	
INTERPRET GEOMETRIC TOLERANCING PER:			
MATERIAL			
FINISH			
DO NOT SCALE DRAWING			

TITLE:  
**CEDARBURG MENORAH**

SIZE	DWG. NO.	REV
<b>B</b>	<b>MENORAH</b>	

SCALE: 1:20 WEIGHT: SHEET 1 OF 1

4

3

2

1



**CEDARBURG  
CHANUKAH WALK**  
THE GARDEN  
CITY AND  
RECREATION  
DEPARTMENT  
WED, DEC 21  
7PM  
11PM  
WWW.CEDARBURG.IL.GOV

**Cedarburg's Menorah of Light**  
The Menorah of Light is a symbol of hope and unity. It is a reminder that we are all part of the same community and that we can all make a difference. The Menorah of Light is a symbol of hope and unity. It is a reminder that we are all part of the same community and that we can all make a difference.





13ft

8ft

4ft 11 in

**BADGER SURVEYING CO., INC.**

REGISTERED LAND SURVEYORS  
**MILTON H. SCHMIDT, Pres.**  
**CLARENCE H. PIEPENBURG, Vice-Pres.**  
**JAMES A. EIDE, Sec.-Treas.**

PHONE FLAGSTONE 4-9080  
 7257 N. 51st STREET  
 MILWAUKEE 23, WIS.

**PLAT OF SURVEY**

*Orig. Plat*

Property at 110-112 N. Washington Avenue Harry Sorweide- Owner  
 Legal Description: The South 1/2 of Lot 12, in Block 2, in Plat of Village of Cedarburg as laid out by Hilgen, Schroeder and Others, in the South East 1/4 of Section 27, Township 10 North, Range 21 East, in the City of Cedarburg, Ozaukee County, Wisconsin.

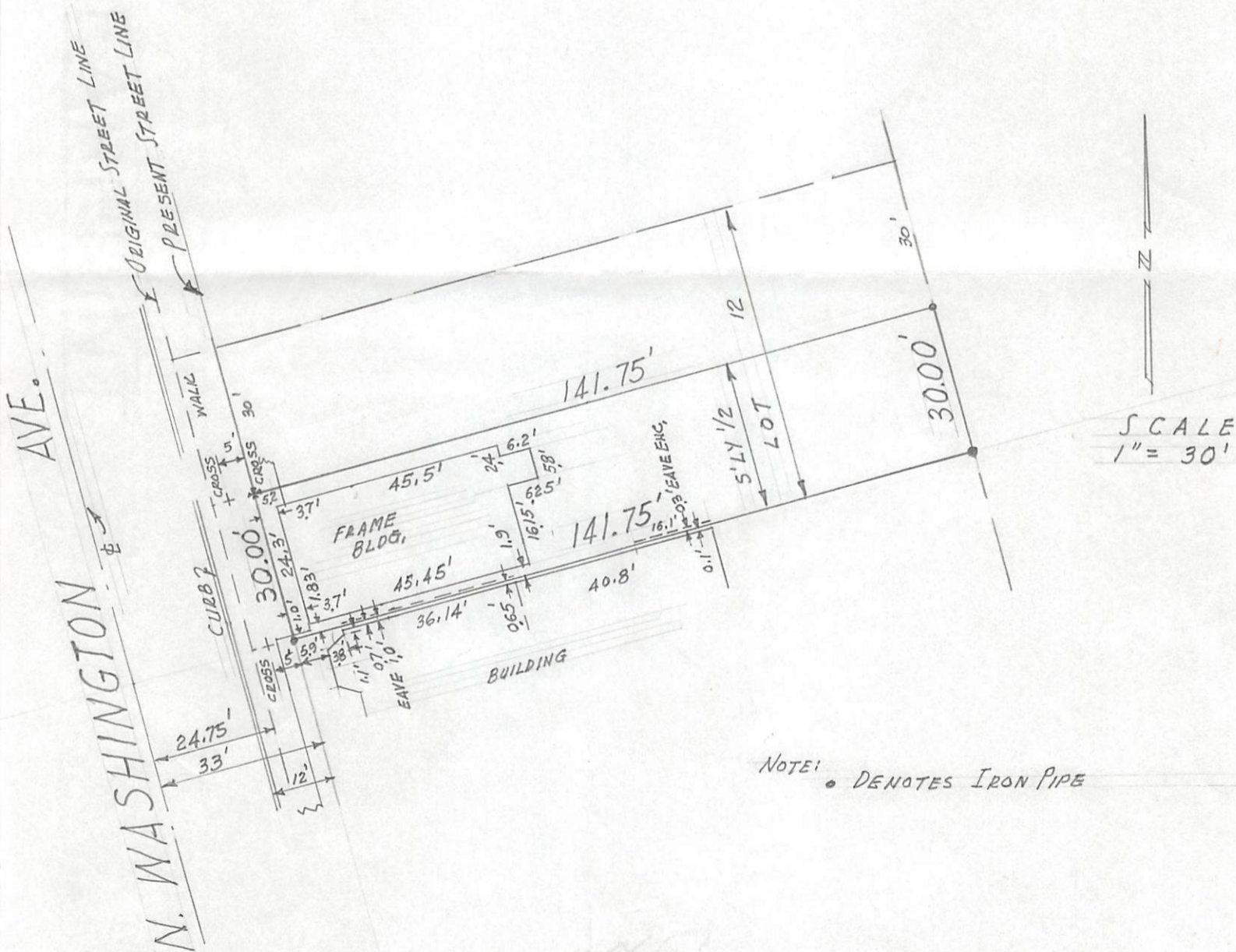

Prepared for HARRY SORWEIDE

State of Wisconsin, }  
 County of Milwaukee } ss.

I hereby certify that on the 25<sup>TH</sup> day of SEPTEMBER, 1963, I have accurately surveyed the above described property and that the above plat is a correct representation thereof and shows the exterior boundary lines and location of buildings and other improvements on said property and the correct measurements thereof.

Plat No. 63-677

Signed Clarence H. Piepenburg  
 Registered Land Surveyor